

Fast Jack[®]

COMMERCIAL

Patent #6,360,491

Flashable Roof Stanchion

The patented design of the **Fast Jack[®]** is now available in an industrial size for large roof load applications. This industrial grade stanchion offers a full 4,250 lbs. of strength using 2 ea. 3/8" x 4" stainless steel lag bolts! Like the Residential **Fast Jack[®]**, the Commercial **Fast Jack[®]** offers a primary lag bolt that resides beneath the removable stanchion, where the most support is offered.

(Design covered under pat. #6,360,491)

Accepts one or two 3/8" lag bolts of your choice length and features an optional leveling kit to adjust for uneven roofs. Fully integrates with commercially available steel strut. Heavier construction supports significantly larger loads.

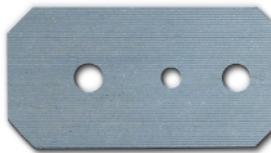

Serrated base designed to grip the roof deck to prevent slipping during installation.

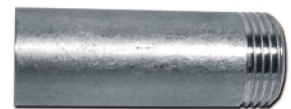

Commercial Post



Commercial Base

The **Fast Jack[®]** design is covered under Pat. #6,360,491

Laboratory tested to
4,250 lbs.
using 2 ea. 3/8" x 4"
Stainless Steel
lag bolts

Available Sizes:

4" High Part# **CFJ-400**

For standard aluminum roof flashings or in areas where a lower elevation of the array is desired

6" High Part# **CFJ-600**

For use with lead flashings or in areas where a higher elevation of the array is desired

Leveling kit Part# **CFJ-LEVEL**

For use with standard outdoor rated strut to adjust for minor roof variances

Residential **Fast Jack[®]** also available (rated at 1,200 lbs.)

Benefits of the Commercial **Fast Jack[®]**

- Removable post makes installation on existing roofs/retrofit quick and easy
- Patented design locates the lag bolt directly under the stanchion providing superior strength values. Secondary bolt in front of base provides extra strength values when desired
- Fast & easy to install - saves time and labor costs
- Precision machined from extruded aluminum, there are no welds to corrode or break
- Significantly lighter than steel for installer convenience and reduced shipping costs
- Integrated drill guide insures perfect pilot holes every time - minimizes the possibility of splitting roof rafters
- Base design allows virtually any roof flashing to install flat on the roof deck

The Commercial **Fast Jack[®]** fits under most standard flashings

Integrated pilot drill guide insures accurate drilling every time!

1.5" Round post is threaded 3" into the center to accommodate for the leveling feature (leveling kit sold separately)

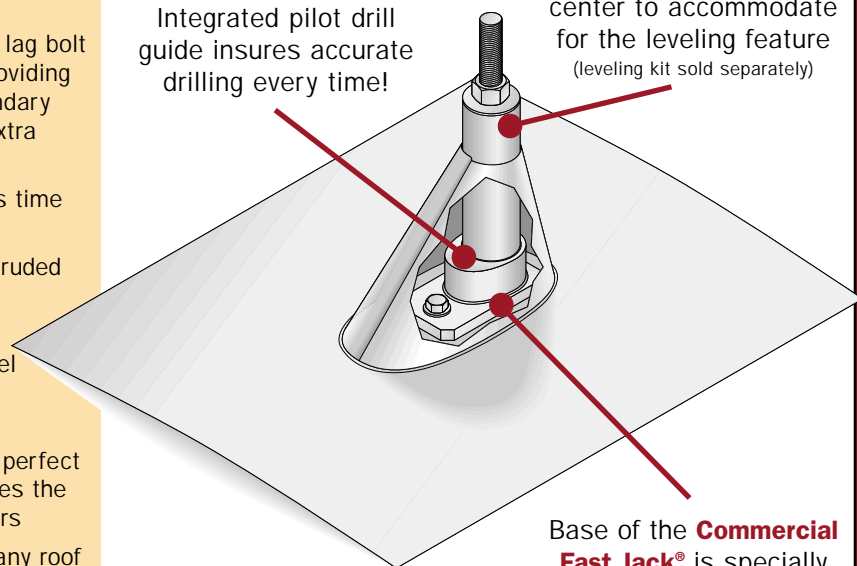

Base of the **Commercial Fast Jack[®]** is specially fabricated to fit under most standard flashings

USED FOR MOUNTING:

- Solar Panels
- HVAC Equipment
- Communication Equipment
- Virtually anything needing structural attachment to a roof!

professional
SOLAR
products inc.

(800) 84-SOLAR

(805) 383-0802-fax
4630 Calle Quetzal
Camarillo, CA 93012

View more info on our website at:

www.RoofTrac.com
/fastjack.htm

Specifications

Optional leveling feature allows for minor adjustments to compensate for uneven roof-tops when using strut.

Leveling kit sold separately from the **Fast Jack®**

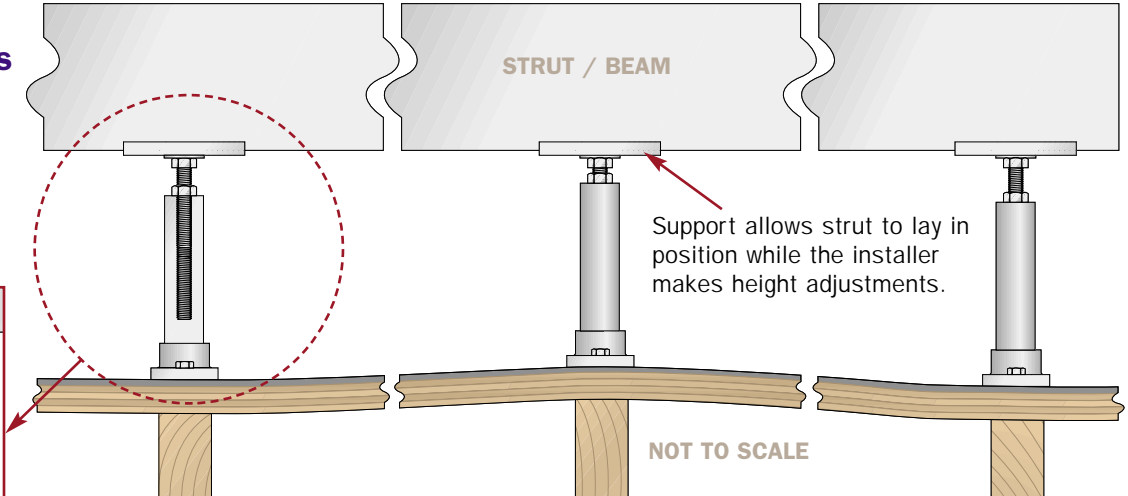
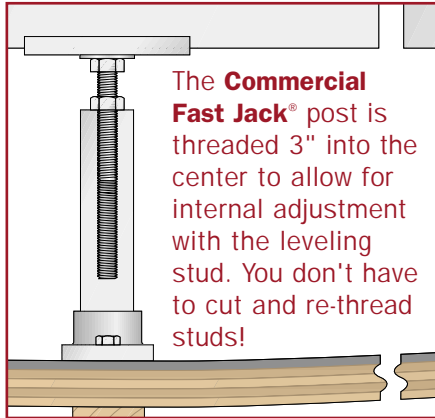

MACHINED FROM SOLID 6061 ALUMINUM.
Eliminates the possibility of leaking because of faulty welds!

TEST DATA AVAILABLE

Pull tested by an independent and accredited testing laboratory to 4,250 lbs. using 2 ea. 3/8" x 4" Stainless Steel lag bolts. Test structure was attached to a 4"x 4" simulated wood beam. Report available upon purchase of product.

MEASUREMENTS / SPECIFICATIONS

BASE: 2" x 3.5" Notched at corners to fit under a standard flashing. #6061 Aluminum

POSTS: CFJ-400 1.5" diameter x 3.75" long
CFJ-600 1.5" diameter x 5.75" long
Posts are threaded 3" into the core for leveling kit usage. #6061 Aluminum

HARDWARE: Hardware is not included with the **Commercial Fast Jack®**. Leveling kit hardware sold separately

LEVELING KIT: leveling kit components
1/2" x 4" Stainless Steel full threaded stud
1/2" Stainless Steel hex nuts
1/2" Stainless Steel Flat Washers
2" x 3" Anodized Aluminum Strut Support

SHIP WEIGHT:

CFJ-400 (Base & Post 1 ea.) 1.2 lbs.
CFJ-600 (Base & Post 1 ea.) 1.8 lbs.

PACKAGING

The **Commercial Fast Jack®** and leveling kit are available in bare bundle packaging only. Quantities are ordered per each however we package each component together in bulk boxes in exact quantities ordered. Boxes are labeled on the pallet for easy installer navigation.

